



Installation and Maintenance

"KD" Series Float and Thermostatic Steam Traps, Condensate Controllers and Liquid Drainers

This bulletin should be used by experienced personnel as a guide to the installation and maintenance of "KD" Series Float and Thermostatic Steam Traps, Condensate Controllers and Liquid Drainers. Selection or installation of equipment should always be accompanied by competent technical assistance. We encourage you to contact Armstrong or its local representative if further information is required.

Armstrong "KD" Series steam traps, condensate controllers and liquid drainers have capacities to 142,000 lb/hr of hot condensate. The inlet and outlet connections are 2", 2-1/2" and 3" NPT. The maximum allowable pressure is 300 psig.

Maximum Operating Pressure	
Model	PSIG
30KD8	30
50KD10	50
300KD10	300
300KD12	300

Installation

1. Series "KD" steam traps, condensate controllers and liquid drainers have individual requirements for installation.
 - A) **Float and Thermostatic Steam Trap**
Install the trap so that its inlet connection is below the liquid level in the equipment to be drained. Figure 1 shows the recommended piping method.
 - B) **Condensate Controller**
The condensate controller's ability to handle flash steam enables it to operate efficiently with siphon drained equipment. Figure 2 shows the recommended piping method.
 - C) **Liquid Drainer**
Install the liquid drainer with its inlet connection below the liquid level in the equipment to be drained. Figure 3 shows the recommended piping for a liquid drainer.
2. Before installing any trap, blow down the piping that leads to the trap's inlet. Be sure the maximum operating pressure (MOP) of the unit is adequate for the installation.
3. Set the unit as shown in Figures 1, 2, or 3 with the flange resting on the floor or on a platform for support. Then install and tighten the inlet and discharge piping to secure the unit in its operating position. Use good piping practices to avoid excessive strain on the piping.
4. To allow for maintenance and provide maximum service, install a valve on each side of the unit, and a strainer ahead of the inlet. All valves should be of the full ported type to avoid restricting flow.

Note: Use good piping practices. Make inlet piping as short as possible with a minimum of elbows and other restrictions. Install a dirt pocket in the line ahead of the unit as shown in Figures 1 and 3.

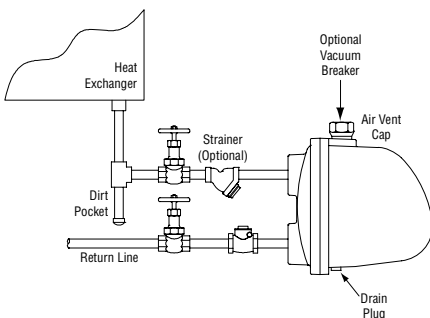

Steam Trap
Figure 1

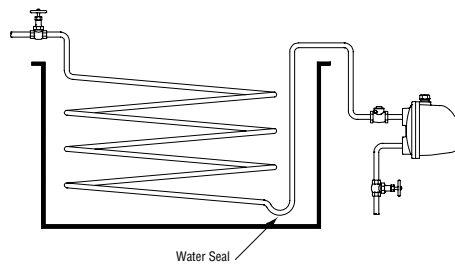

Condensate Controller
Figure 2

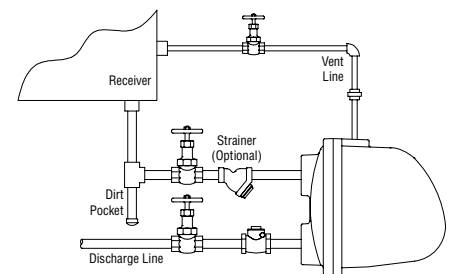

Liquid Drainer
Figure 3

5. **Liquid Drainers** must be back vented to avoid air binding. Do not reduce the pipe size to less than 1" for the back vent. Connect as shown in Figure 3. Use a full-ported valve in the back-vent line. Remember that the pressure in the drainer is the same as in the unit drained. Only the difference in liquid levels produces flow. Minimize fittings and length of pipe between the vessel and the drainer.
6. If condensate is discharged to an overhead return; ensure that adequate differential pressure exists across the trap to elevate the condensate. Install a check valve in the discharge piping near the unit to prevent backflow when the system is not in operation.
7. Under conditions where the load may approach the maximum capacity of the trap, it is recommended that the size of the discharge piping be increased as close to the trap as practical. The larger pipe is required to handle the choking effects of the flashing condensate at the trap outlet, thus reducing the backpressure at the trap. Also, consideration should be given to the condensate system pressure when sizing the discharge piping. Contact Armstrong or its local representative if further information is required.
8. Series "KD" units do not require priming. They are ready for operation when installed.

Maintenance

Check the internal mechanism of these units for damage or wear at least once a year.

1. Opening the unit

- A) Close the valves in both supply and discharge lines. If the unit is hot, allow it to cool. (Liquid drainers: close the valve in the back-vent line.)
- B) Remove the drain plug from the bottom of the body and allow the liquid to drain.

CAUTION: Do not attempt to remove the body without first removing the thermostatic air vent or fixed orifice and coupling.

- C) Before removing the body:

a. Steam Trap

Remove the air vent cap (1-1/2" plug) from the top of the body. When the cap is removed, the thermostatic air vent extends through the top of the body. Using a spanner wrench or pliers, remove the thermostatic air vent and gasket. Inspect the vent for damage.

The valve should be away from the valve seat. If you have the facilities, place the air vent in a pan of water and heat it to boiling. The valve should close. If the bellows is collapsed or ruptured, or the valve and seat of the vent are eroded, discard it and install a new one.

If the unit includes a vacuum breaker, it is located in the air vent cap. Blow through the vacuum breaker from atmosphere side to be sure that it opens; suck air from that same side to be sure that it closes tightly. If the vacuum breaker does not operate properly, discard it and install a new one.

b. Condensate Controller

Remove the air vent cap from the body. Remove the fixed orifice air vent and the coupling from the air relief tube.

c. Liquid Drainer

Disconnect the back-vent or secondary steam piping from the drainer body.

- D) Put blocks under the body of the unit to support it (wt. approx. 60 lbs.) and remove the 10 bolts that attach the body to the cap. To facilitate handling, screw a lifting lug into the 1-1/2" NPT hole in the top of the body. A hoist can be attached to the lifting lug.
- E) Carefully pull the body away from the cap, lifting slightly as you pull. Remove and discard the old gasket.

F) Inspect all of the moving parts. If any parts are worn or damaged replace the complete mechanism. See Figures 4 and 5.

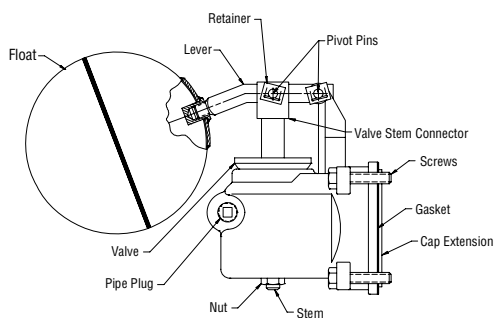

**Cap Extension and Assembly
for 30KD8 and 50KD10
Figure 4**

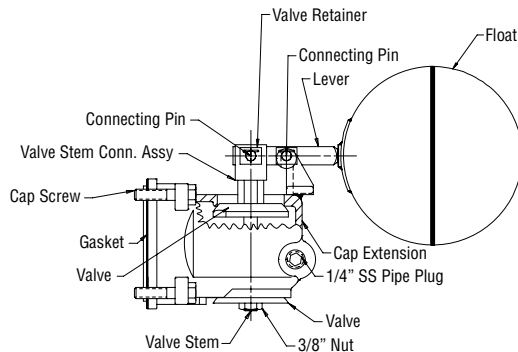

**Cap Extension and Assembly
for 300KD10 and 300KD12
Figure 5**

2. Removing the Mechanism for Replacement

- A) Unscrew the four mounting screws.
- B) Remove the mechanism from the cap.
- C) Remove the gasket and clean the gasket surface.

3. Installing the New Mechanism if Required

- A) Place a new gasket between the cap and mechanism.
- B) Place the mechanism against the gasket.
- C) Install the four mounting screws.
- D) Tighten the mounting screws so that the gasket seals uniformly.

4. Reassembly of Trap

- A) After inspection and repair, clean the gasket surfaces and place a new gasket between the body and the cap. Replace the body carefully to avoid damaging the internal parts. Install and tighten the 10 bolts to 140 ft. lbs. (See Figure 6 for bolt tightening sequence.)
- B) Screw the drain plug into the bottom of the body and tighten it securely.

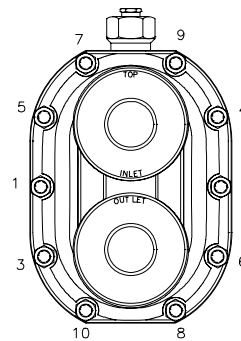

**Bolt Tightening Sequence
Figure 6**

a. Steam Trap

Place the thermostatic air vent, with gasket installed, into the coupling at the top of the air relief tube. Tighten with a spanner wrench or pliers. Screw the air vent cap into the top of the body and tighten the cap with a wrench.

b. Condensate Controller

Screw the fixed orifice and coupling onto the upper end of the air relief tube. Screw the air vent cap into the top of the body and tighten with a wrench.

c. Liquid Drainer

Reconnect the back-vent piping.

- C) Open the valves in the supply and discharge line. For Liquid Drainers, also open the valve in the back-vent line. Check the equipment for normal operation.

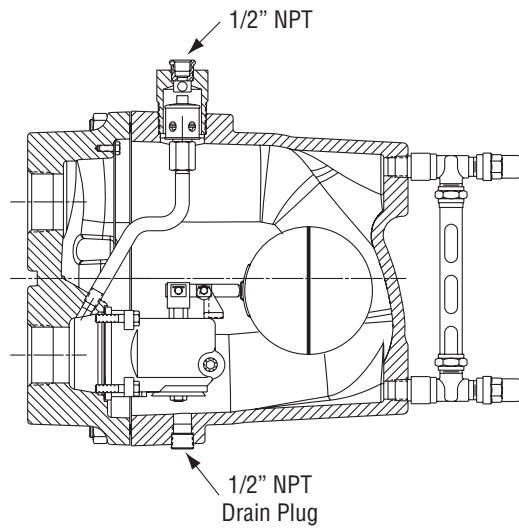

Steam Trap
Figure 7

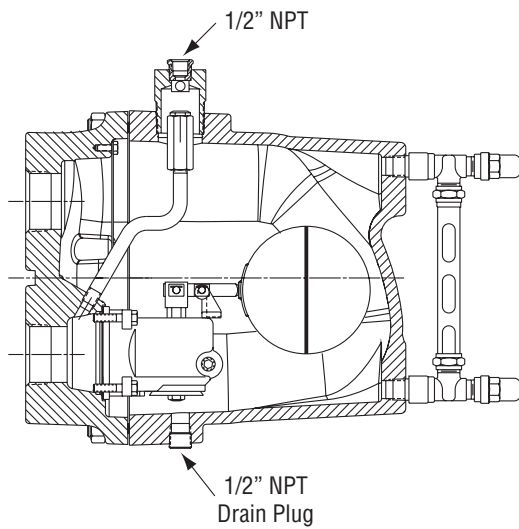

Condensate Controller
Figure 8

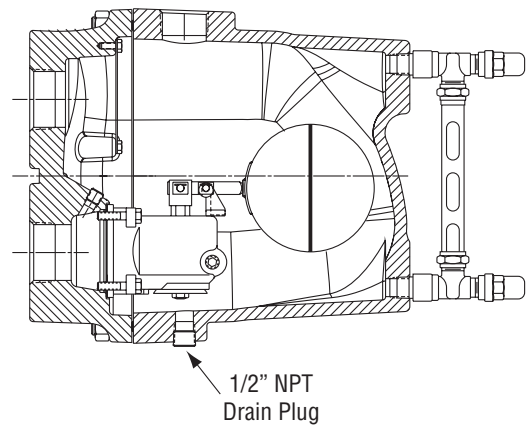

Liquid Drainer
Figure 9



Überreicht durch:
ASA Horst Wieber GmbH, Werner-von-Siemens-Str. 17, 28816 Stuhr
Tel.: 0421/565727-0 • E-Mail: info@asa-germany.de • www.asa-germany.de