

INSTALLATION AND MAINTENANCE INSTRUCTIONS FLOAT & THERMOSTATIC STEAM TRAPS FLT50 – FLT65

GENERAL

- These instructions must be carefully read before any work involving products supplied by VALSTEAM ADCA ENGINEERING S.A. is undertaken.
- The installation procedure is a critical stage in a life of a float trap and care should be taken to avoid damage to the float trap or equipment.

Warning!

- At start up, the presence of small particles in the water (dirt, scale, weld splatters, etc) may cause an imperfect closure of the seat. If this occurs, proceed to an accurate cleaning.
- Do not touch the equipment without appropriate protection during working operation because it may conduct heat if the used fluid is at high temperature.
- Before starting maintenance be sure that the equipment is not pressurized or hot.
- The equipments must be used within the working temperature and pressure limits laid down for them, otherwise they may fail (refer to nameplate and/or IS- Information Sheet).
- Do not remove the nameplate attached to the equipment. Serial number and other useful information is stamped on it.

INSTALLATION



- Before to install remove plastic covers placed on flanges or connection ends. The equipment has an arrow or Inlet/Outlet designations. Be sure that it will be installed on the appropriate direction.
- Install the steam trap in the point of the system, where the condensate tends to collect. It must be installed with the float lever in horizontal plane, so that it rises and falls vertically. An ADCA strainer should be installed upstream of the trap.

LIMITING CONDITIONS	
PMA: Max. allowable pressure	16 bar
TMA: Max. allowable temperature	300 °C
PMO: Max. operating pressure	12 bar
TMO: Max. operating temperature	250 °C

MAX. DIFFERENTIAL PRESSURE	
FLT50 & FLT65	12 bar

Installation area requirements:

- The installation area should have easy access and provide enough space for maintenance and removing operations.
- The installation area should have the necessary firing system to prevent damage of the equipment due to over temperature/pressure cause by fire.



MAINTENANCE

- We recommend that the float steam traps are serviced as necessary. Steam traps should be checked periodically (at least yearly), to verify that they are operating correctly and to clean the internal parts and screen (if any).
- When reassembling make sure that all gasket faces are clean and always use a new gasket. Tighten cover bolts uniformly in a diagonal sequence.
- For further information refer to the relevant FLT50 & FLT65 brochure or consult our Sales Office.

CE Marking:

This product has been designed for use on water and steam which are in Group 2 of the European Pressure Equipment Directive 97/23/EC and it comply with those requirements.

The product carries the CE mark when falling in category 1 and above.

MODEL	SIZES	CATEGORY
FLT 50	DN 50	SEP
FLT 50	DN 65	1
FLT 65	DN 65 - 100	1

PARTS LIST FOR FLT50, DN50-DN65

Code	Designation	SizeTrap	Pos.Nr.	Qty.
A.92.6403.050	Valve, seat, float & gasket	DN50-65	3, 4, 5, 6, 7	1 Set
A.92.6403.150	Float & gasket	DN50-65	3, 7	1 Set
A.92.6403.250	Air vent & gasket	DN50-65	3, 8	1 Set

Recommended tightening torques FLT50, DN50-DN65

Pos.Nr.	Size	Nm
8	DN 50 - 65	50 - 55
9	DN 50 - 65	80 - 85

Remarks: Tighten cover bolts uniformly.

PARTS LIST FOR FLT65, DN65-DN100

Code	Designation	SizeTrap	Pos.Nr.	Qty.
A.92.6403.065	Valve, seat, float & gasket	DN50-65	3, 4, 5, 6, 7	1 Set
A.92.6403.165	Float & gasket	DN50-65	3, 7	1 Set
A.92.6403.265	Air vent & gasket	DN50-65	3, 8	1 Set

Recommended tightening torques FLT65, DN65-DN100

Pos.Nr.	Size	Nm
8	DN 65 - 100	50 - 55
9	DN 65 - 100	80 - 85

Remarks: Tighten cover bolts uniformly.

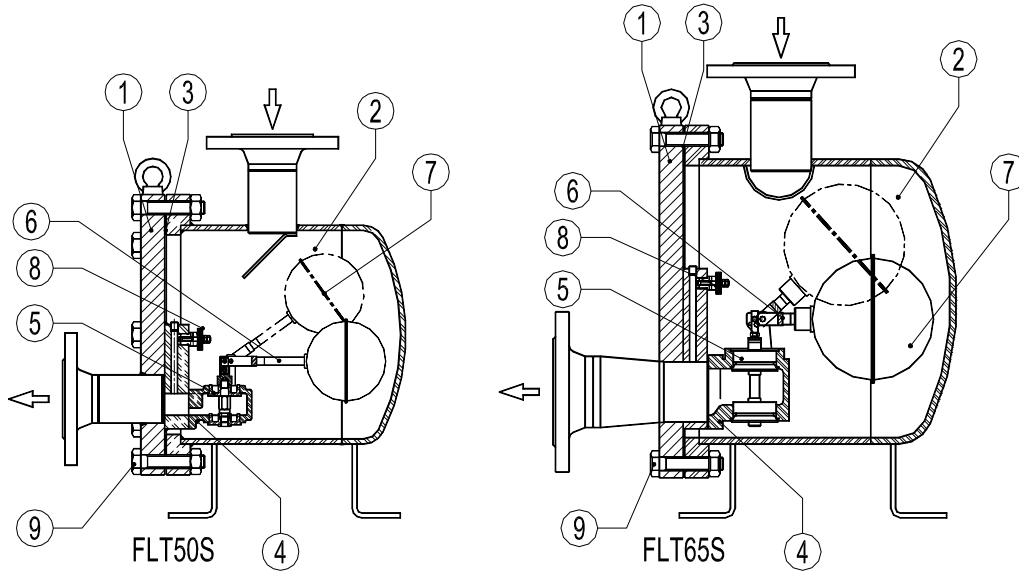

ATTENTION

- **LOSS OF WARRANTY:** Total or partial disregard of above instructions involves loss of any right to warranty.